



ENABLING EFFICIENT AND OPERATIONAL MOBILITY IN LARGE HETEROGENEOUS IP NETWORKS

Softwires implementation



Jordi Palet, Consulintel
(jordi.palet@consulintel.es)
v1.0



Development done for IPv4 MIPv6 Interworking

- The work deals with building a firmware with the following features:
 - Softwires Concentrator (SC) capable
 - ❑ Linksys will be able to work as IPv6 TEP
 - ❑ MN will setup the IPv6 tunnel by using Softwires and the Linksys as SC
 - It is a standalone component handled by Consulintel
- Both the the SI (MN) and the SC (NAS) are available
- MIPv6 runs over the Softwires tunnel



Softwires as solution for IPv4 MIPv6 Interworking (I)

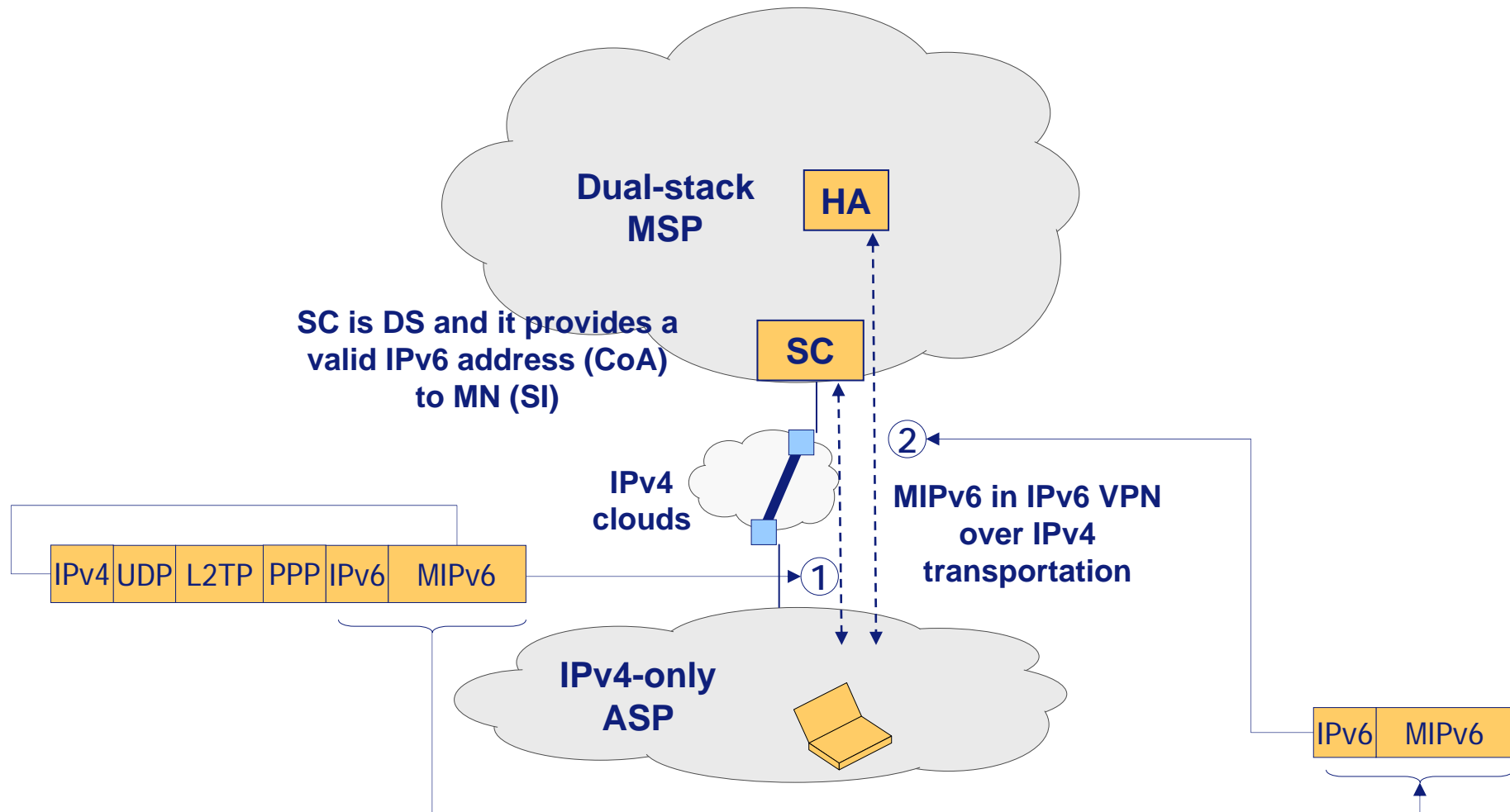



Softwires as solution for IPv4 MIPv6 Interworking (II)

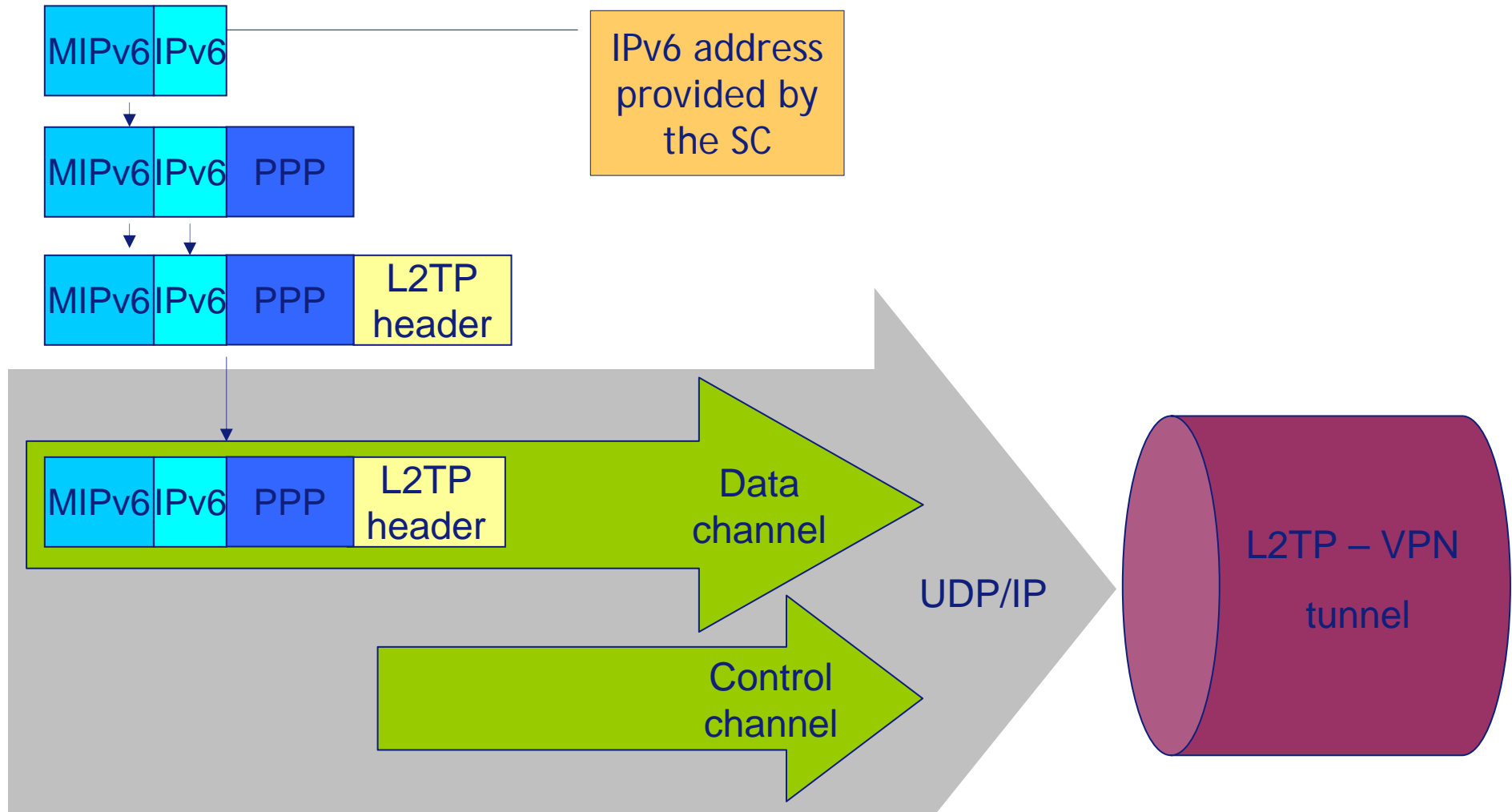



IPv4 interworking with softwires

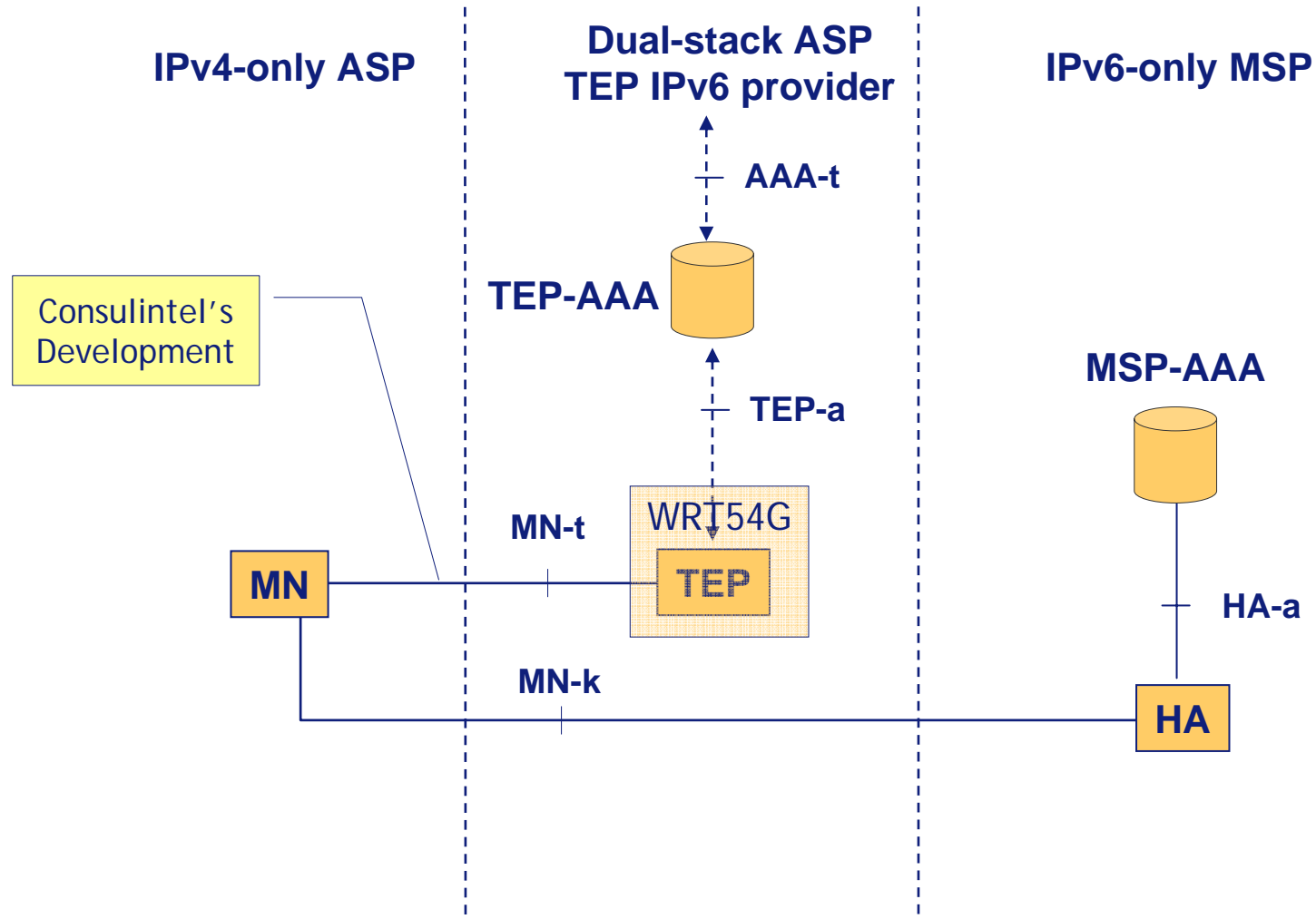



Issues

- The Softwires tunnel has to be reestablished every time the MN changes its location (i.e. IPv4 address)
- This means that some extra work needs to be done in the user side
- Working on a possible Internet Draft on this

Implementation details

- SC implemented into the Linksys WRT54G access router
 - The firmware was modified to support the softwires protocol (both IPv4 in IPv6 and IPv6 in UDP/IPv4), DHCPv6, MIPv6 and many other features
 - Available also for other platforms:
 - ☐ Linux, BSD and possibly Windows
- SI implemented into the MN
 - Linksys
 - Ubuntu, kernel 2.6.16 with MIPv6 kernel patch

Integrated bootstrapping with DHCPv6

- Working on providing a NAS platform to show MIPv6 bootstrapping in integrated scenario:
 - DHCPv6 available
- WRT54G as access point (NAS) by Linksys
- The work deals with building a firmware with the following features:
 - For integrated scenario with DHCPv6 available
 - IPv6 capable
 - 802.1x capable
 - DHCPv6 relay capabilities
 - Both DHCPv6 server and client also provided
 - For IPv4 interworking
 - Softwires server capable. It is a standalone component handled by Consulintel.



Steps for MIPv6 bootstrapping with DHCPv6

